

Series H20

- Ultra-reliable design using long-life bearings
- Unbreakable code disk available
- Complete electrical protection and noise immunity tested to EN5002-2
- Available with environmental sealing to NEMA4 / IP66

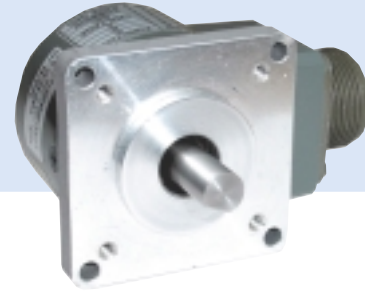

APPLICATION/INDUSTRY

The Dynapar brand Series H20 is a rugged, reliable and economical encoder for industrial motion applications.

DESCRIPTION

Models with resolutions of 1024 or less are equipped with an unbreakable code disk that meets the demands of the most severe shock and vibration generating processes; use of long life bearings keep tough loads from disrupting internal alignment, avoiding failure due to the disk "crashes" so typical in competitive encoders. Protection against installation problems such as wiring errors prevents the encoder from damage, while immunity to electrical noise keeps the encoder signals intact. A NEMA4 / IP66 sealing option protects against damage from contamination.

Packaged in the industry standard 2.0" enclosure, the Series H20 offers a variety of mechanical options: servo or face mounting, 1/4" or 3/8" shafts, and several types of pilots. Electrical options include: resolutions from 1 to 2540 pulses/revolution; unidirectional or bidirectional operation with optional index; single ended open collector or push-pull outputs, or differential line drivers; and connector or cable exit terminations.

The Series H20 utilizes the latest technology optical emitters and sensors, surface mount assembly and precisely fabricated metal components to deliver high reliability and performance in a compact and economical package.

FEATURES AND BENEFITS

Mechanical / Environmental Features

- Unbreakable, code disk and long life bearings
- Extended temperature range option
- Industry Standard, Size 20 Form Factor
- NEMA4 / IP66 washdown rating option

Electrical Features

- Noise Immune to ESD, RFI and electrical transients
- High current outputs
- Over-Voltage protection
- Reverse Voltage protection
- Output Short-Circuit Protection

SPECIFICATIONS

STANDARD OPERATING CHARACTERISTICS

Code: Incremental
Resolution: 1 to 2540 PPR (pulses/revolution)
Accuracy: (Worst case any edge to any other edge) ≤ 1024 PPR (metal disk): ± 7.5 arc-min. > 1024 PPR (glass disk): ± 2.5 arc-min.
Format: Two channel quadrature (AB) with optional Index (Z) and complementary outputs
Phase Sense: A leads B for CCW shaft rotation as viewed from the shaft end of the encoder
Quadrature Phasing: $90^\circ \pm 22.5^\circ$ electrical
Symmetry: $180^\circ \pm 18^\circ$ electrical
Index: $180^\circ \pm 18^\circ$ electrical (gated with B low)
Waveforms: Squarewave with rise and fall times less than 1 microsecond into a load capacitance of 1000 pf

ELECTRICAL

Input Power:
 4.5 min. to 26 VDC max. at 80 mA max., not including output loads
Outputs:
 7273 Open Collector: 30 VDC max., 40 mA sink
 7272 Push-Pull and Differential Line Driver: 40 mA sink or source
 4469 Differential Line Driver: 100 mA, sink or source
Frequency Response: 100 kHz min.
Electrical Protection: Overvoltage, reverse voltage and output short circuit protected
Noise Immunity: Tested to EN50082-2 (Heavy Industrial) for Electro Static Discharge, Radio Frequency Interference, Electrical Fast Transients.

CONNECTIONS

Mating Connector:
 6 pin, style MS3106A-14S-6S (MCN-N4);
 7 pin, style MS3106A-16S-1S (MCN-N5);
 10 pin, style MS3106A-18-1S (MCN-N6)
 5 pin, style M12: Cable with connector available
 8 pin, style M12: Cable with connector available

MECHANICAL

Shaft Loading: (at 0.25" from encoder face)
 Resolutions ≤ 1024 PPR: 80 lbs. radial, axial
 Resolutions > 1024 PPR: 40 lbs. radial, axial
Shaft Speed:
 Resolutions ≤ 1024 PPR: 10,000 RPM max.
 Resolutions > 1024 PPR: 5,000 RPM max.
Starting Torque: (max at 25 °C)
 without shaft seal: 1.0 oz-in;
 with shaft seal: 2.0 oz-in
Moment of Inertia: 3.0×10^{-4} oz-in-sec²

Weight: 10 oz. max.

ENVIRONMENTAL

Operating Temperature:
 Standard: 0 to +70 °C;
 Extended: -40 to +85 °C
Storage Temperature: -40 to +90 °C
Shock: 50 G's for 11 milliseconds duration
Vibration: 5 to 2000 Hz at 20 G's
Humidity: to 98% without condensation
Enclosure Rating: NEMA12/IP54 (dirt tight, splashproof); NEMA4/IP66 (dust proof, washdown) when ordered with shaft seal and either MS connector or watertight cable exit

ELECTRICAL CONNECTIONS

Series H20

6, 7 & 10 Pin MS Connectors and Cables - Code 8= 0 to 9, A to M

Connector & mate/accessory cable assembly pin numbers and wire color information is provided here for reference. H20 models with direct cable exit carry the same color coding as shown for each output configuration.

Encoder Function	Cable # 108594-6 Pin Single Ended		Cable # 108595-7 Pin Single Ended		Cable # 108596-7 Pin Dif Line Drv w/o Idx		Cable # 1400635-10 Pin Dif Line Drv w/ Idx	
	Pin	Wire Color	Pin	Wire Color	Pin	Wire Color	Pin	Wire Color
Sig. A	E	BRN	A	BRN	A	BRN	A	BRN
Sig. B	D	ORN	B	ORG	B	ORG	B	ORG
Sig. Z	C	YEL	C	YEL	—	—	C	YEL
Power +V	B	RED	D	RED	D	RED	D	RED
Com	A	BLK	F	BLK	F	BLK	F	BLK
Case	—	—	G	GRN	G	GRN	G	GRN
N/C	F	—	E	—	—	—	E	—
Sig. \bar{A}	—	—	—	—	C	BRN/WHT	H	BRN/WHT
Sig. \bar{B}	—	—	—	—	E	ORG/WHT	I	ORG/WHT
Sig. \bar{Z}	—	—	—	—	—	—	J	YEL/WHT

Cable Configuration: PVC jacket, 105 °C rated, overall foil shield; 3 twisted pairs 26 AWG (output signals), plus 2 twisted pairs 24 AWG (input power)

5 & 8 Pin M12 Accessory Cables when Code 8= N to R

Connector pin numbers and cable assembly wire color information is provided here for reference.

Encoder Function	Cable # 112859-5 Pin Single Ended		Cable # 112860-8 Pin Single Ended		Cable # 112860-8 Pin Differential	
	Pin	Wire Color	Pin	Wire Color	Pin	Wire Color
Sig. A	4	BLK	1	BRN	1	BRN
Sig. B	2	WHT	4	ORG	4	ORG
*Sig. Z	5	GRY	6	YEL	6	YEL
Power +V	1	BRN	2	RED	2	RED
Com	3	BLU	7	BLK	7	BLK
Sig. \bar{A}	—	—	—	—	3	BRN/WHT
Sig. \bar{B}	—	—	—	—	5	ORG/WHT
*Sig. \bar{Z}	—	—	—	—	8	YEL/WHT

* Index not provided on all models. See ordering information

Cable Configuration: PVC jacket, 105 °C rated, overall foil shield; 24 AWG conductors, minimum

DIMENSIONS

Series H20

Code 3: Housings

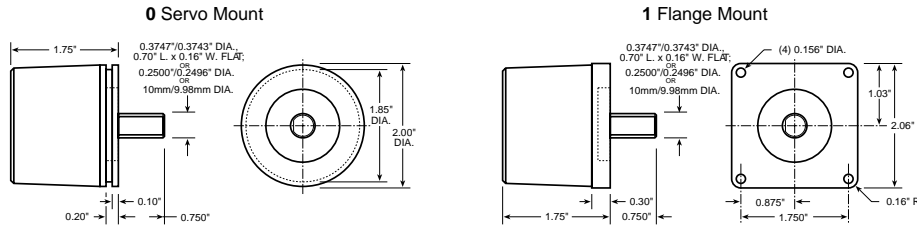

Code 5: Face Mounts

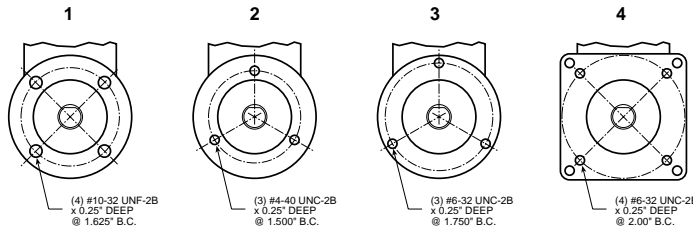

Code 6: Pilots

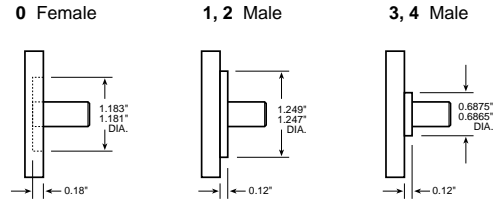

Code 8: Terminations

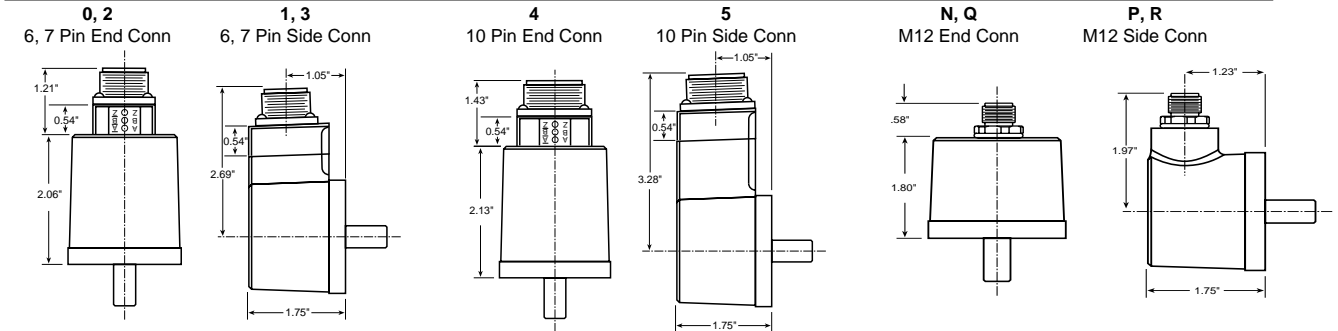

Code 8: 0-5 dimensions shown with LED Output Indicator Option (Code 9: PS)

6, 8, A, C, E, G
End Exit Cable

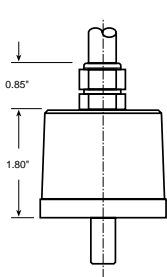

7, 9, B, D, F, H
Side Exit Cable

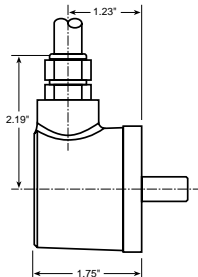

ORDERING INFORMATION

Series H20

INDUSTRIAL

Code 1: Model	Code 2: PPR	Code 3: Housing	Code 4: Shaft	Code 5: Face Mount	Code 6: Pilot, Seal	Code 7: Electrical	Code 8: Termination	Code 9: Options
H20 <input type="checkbox"/>	<input type="checkbox"/> <input type="checkbox"/> <input type="checkbox"/> <input type="checkbox"/>	<input type="checkbox"/>	<input type="checkbox"/>	<input type="checkbox"/>	<input type="checkbox"/>	<input type="checkbox"/>	<input type="checkbox"/>	<input type="checkbox"/>
Ordering Information								
1 Unidirectional	0001 0500 0005 0512 0010 0600	0 Servo Mount	0 3/8" Dia. Shaft with flat	0 no face mount	0 1.18" Dia. Female Pilot	0 5-26V in, 5-26V Open Collector out	0 6 Pin Conn, End Mount	available when Code 8 is 0 to 5: PS LED Output Indicator
2 Bidirectional	0012 0800 0050 0900 0060 1000 0086 1024 0100 1200 0120 1250 0125 1270 0180 1500 0200 1600 0240 1800 0250 1968 0254 2000 0256 2048 0300 2400 0360 2500 0400 2540	1 Flange Mount	1 1/4" Dia. Shaft, no flat	available when Code 3 is 0: 1 (4) #10-32 @ 1.63" BC 2 (3) #4-40 @ 1.50" BC 3 (3) #6-32 @ 1.75" BC	1 1.25" Dia. Male Pilot 2 1.25" Dia. Male Pilot with Shaft Seal 3 0.69" Dia. Male Pilot	1 5-26V in, 5-26V Open Collector out with 2.2 kΩ Pullups 2 5-26V in, 5-26V Push-Pull out A Same as "0" with extend. temp range B Same as "1" with extend. temp range C Same as "2" with extend. temp range	1 6 Pin Conn, Side Mount 2 7 Pin Conn, End Mount 3 7 Pin Conn, Side Mount 4 10 Pin Conn, End Mount 5 10 Pin Conn, Side Mount 6 18" Cable, End Exit 7 18" Cable, Side Exit 8 36" Cable, End Exit 9 36" Cable, Side Exit A 10' Cable, End Exit B 10' Cable, Side Exit J 25' Cable, End Exit K 25' Cable, Side Exit N 5 Pin M12 Connector, End Mount P 5 Pin M12 Connector, Side Mount Q 8 Pin M12 Connector, End Mount R 8 Pin M12 Connector, Side Mount	
3 Bidirectional with Index			4 10mm Dia. Shaft, no flat	available when Code 3 is 1: 4 (4) #6-32 @ 2.00" BC	4 0.69" Dia. Male Pilot with Shaft Seal	available when: Code 1 is 1 or 2 and Code 8 is 2 through M, Q or R; or Code 1 is 3 and Code 8 is 4 thru M, Q or R: 3 5-26V in, 5-26V Differential Line Driver out (7272) 4 5-26V in, 5V Differential Line Driver out (7272) 5 5-26V in, 5V Differential Line Driver out (4469) 6 5-15V in, 5-15V Differential Line Driver out (4469) D Same as "3" with extend. temp range E Same as "4" with extend. temp range	available when Code 6 is 2 or 4: C 18" Sealed Cbl, End Exit D 18" Sealed Cbl, Side Exit E 36" Sealed Cbl, End Exit F 36" Sealed Cbl, Side Exit G 10' Sealed Cbl, End Exit H 10' Sealed Cbl, Side Exit L 25' Sealed Cbl, End Exit M 25' Sealed Cbl, Side Exit	